

Edge 2 | Single Board Computer
Edge 2 Kit | IoT Edge Computer

User Manual

Get Started with

<https://www.mixtile.com/docs/>

Changes

Version	Date	Changes	Name
1.0	2021-08-23	First version	VT
1.1	2021-11-12	Add key component specification	VT
1.2	2022-03-14	Add content related to Edge2 Kit	CR
1.3	2022-04-24	Update information of M.2 and Mini-PCIe	CR
1.4	2024-05-08	Update information of High-Definition Multimedia Interface	CR

Index of Contents

CHANGES	– 2 –
1 INTRODUCTION	– 5 –
1.1 PRODUCT DESCRIPTION	– 5 –
1.2 PACKAGE LIST	– 5 –
1.3 MAIN FEATURES	– 5 –
1.4 BLOCK DIAGRAM & PRODUCT OVERVIEW	– 6 –
1.4.1 Block Diagram	– 6 –
1.4.2 Product Overview	– 7 –
1.4.3 Physical Dimensions	– 9 –
1.5 KEY COMPONENT SPECIFICATIONS	– 10 –
1.5.1 MIXTILE Core 3568	– 10 –
1.5.2 Wi-Fi 6 / Bluetooth	– 10 –
1.5.3 MicroSD Socket	– 11 –
1.5.4 M.2 Socket	– 11 –
1.5.5 Mini-PCIe Socket	– 11 –
1.5.6 Gigabit Ethernet	– 12 –
1.5.7 Power Input	– 12 –
1.5.8 USB 2.0/3.0 Host Ports	– 12 –
1.5.9 RS485	– 12 –
1.5.10 Display Support	– 12 –
1.5.11 U.2 Connector	– 13 –
1.5.12 Buttons & LEDs	– 13 –
2 CONNECTORS & PIN ASSIGNMENTS	– 15 –
2.1 DEBUG	– 15 –
2.2 UART	– 15 –
2.3 CAN-IO	– 15 –
2.4 I2C	– 16 –
2.5 5V OUTPUT	– 16 –
2.6 POWER BUTTON CONNECTOR	– 16 –
2.7 RESET BUTTON CONNECTOR	– 16 –
2.8 SPDIF	– 16 –
2.9 RS485	– 17 –
2.10 ADC	– 17 –
2.11 SPEAKER	– 17 –
2.12 DMIC	– 17 –
2.13 MIPI-DSIO	– 18 –
2.14 MIPI-DSI1	– 18 –
2.15 EDP	– 19 –
2.16 CAMERA	– 20 –
2.17 M.2	– 21 –
2.18 MINI-PCIE	– 23 –

2.19	U.2	– 24 –
2.20	SATA POWER	– 26 –
3	SPECIFICATIONS	– 26 –
3.1	ENVIRONMENTAL	– 26 –
3.2	MECHANICAL	– 26 –
4	SUPPORT	– 27 –
4.1	TECHNICAL SUPPORT	– 27 –

1 Introduction

1.1 Product Description

Edge 2 is a high-performance and rich-interface ARM64 single-board computer targeted for a wide range of IoT networking and computing applications. It may apply in networking, computing, controlling, and home entertainment areas for further achievement with the help of multipurpose software. The single-board computer combines a MIXTILE System-on-Module Core 3568, a WLAN+BT wireless module, and plenty of expansion interfaces.

Edge 2 Kit is based on Edge 2, just adds one customizable enclosure and two external Wi-Fi antennas.

1.2 Package list

- 1x MIXTILE Edge 2
- 1x 1m type-c to type-c cable
- 2x 16mm 6dbi 2.4G/5.8G Antennas **(Only Included in Edge 2 Kit)**

1.3 Main Features

- Quad-core Cortex-A55 SoC Processor RK3568 up to 2.0GHz
- 2/4GBytes LPDDR4 SDRAM Memory
- 16/32GBytes eMMC Flash Memory
- 1 Tops NPU
- Wi-Fi 6 802.11ax
- Dual-Mode Bluetooth 5.0
- Support 4G/5G/LoRa/Zigbee module
- 1x Gigabit Ethernet Port
- 1x MicroSD 3.0 Flash Expansion Socket
- 3x USB 2.0/3.0 ports up to 5Gbps
- 1x M.2 Socket: PCIe 3.0, USB 3.0, SIM Socket
- 1x Mini-PCIe Socket: USB2.0, SIM Socket
- 1 x U.2 Socket: SATA/PCIe, SATA, RGMII/SPI/I2S, USB2.0
- 1x High-Definition Multimedia Interface2.0, 1x eDP, 2x MIPI-DSI, and 1x MIPI-CSI
 - 4KP60 H.265/H.264/VP9 video decoder
 - 1080P100 H.264/H.265 video encoder
- 1x RS485, 1x CAN, 1x I2C, and 2x UART
- 3x PDM, 1x SPDIF, 1x Speaker, 1x IR, and 4x ADC
- Real Time Clock with Battery Backup
- 2x power supply ports:
 - Type-C PD3.0 Power input (Max 3A @ 20V)
 - 12V DC/SATA Power input (Max 3A)
- Android 11 Board Support Package
- 0 to +80°C Operating Temperature

1.4 Block diagram & Product overview

1.4.1 Block Diagram

The Block diagram for the Edge 2 single-board computer is shown below with descriptions for each function.

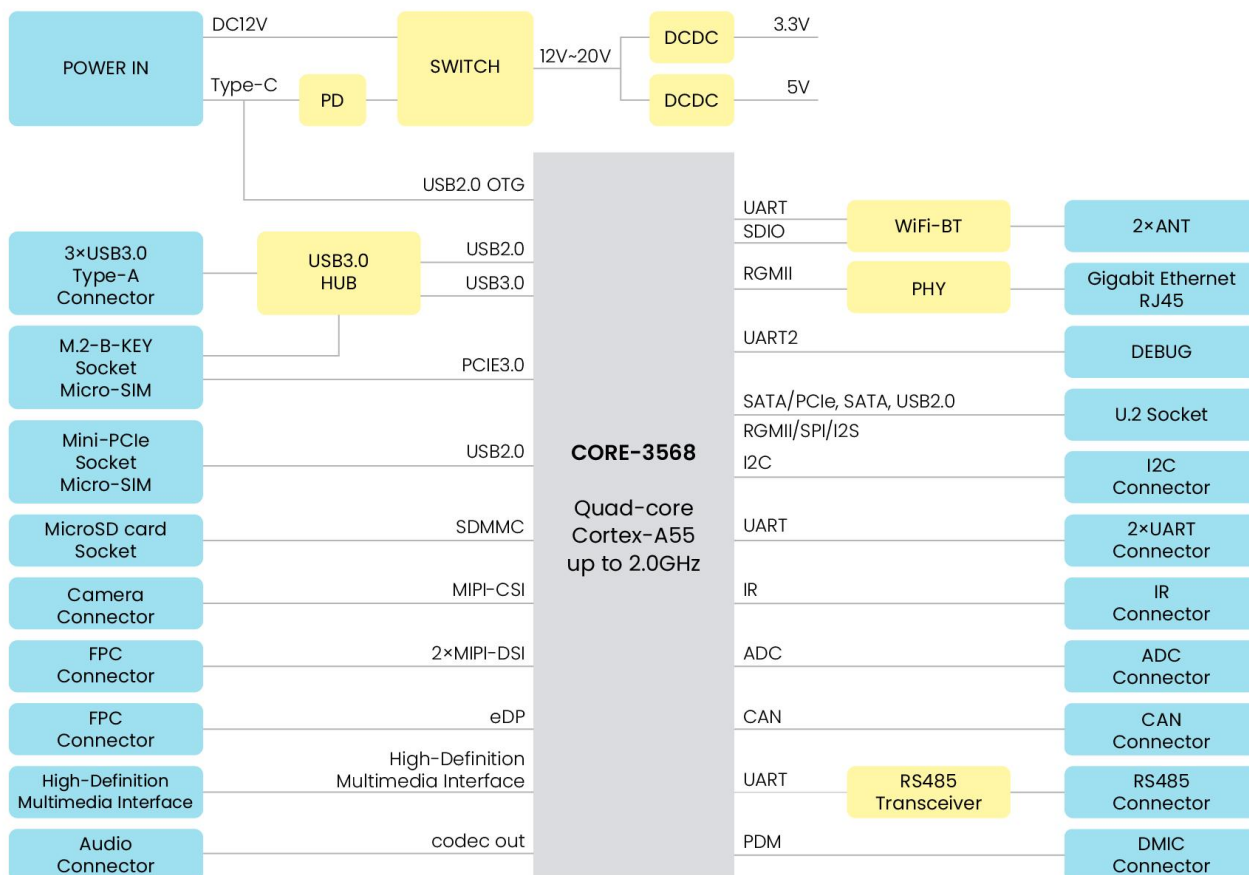

1.4.2 Product Overview

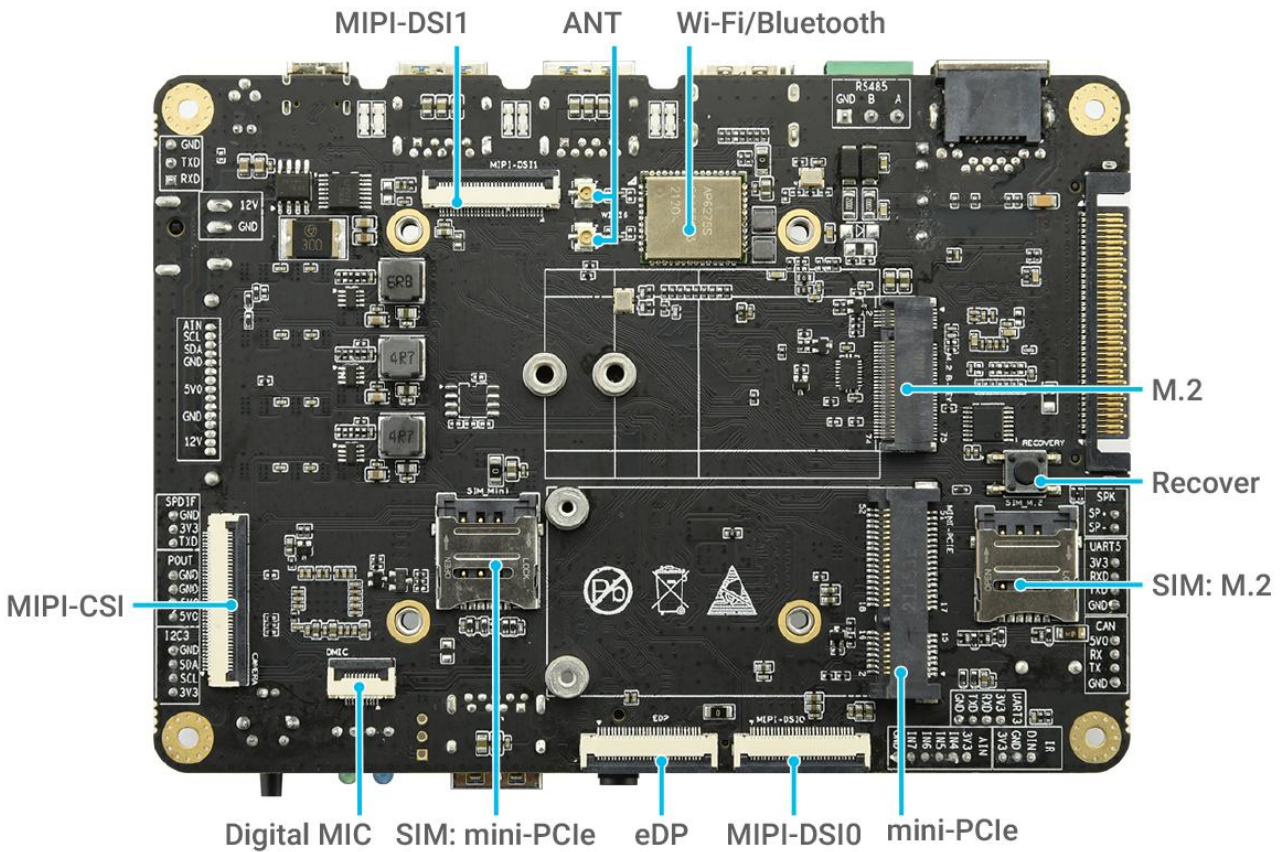
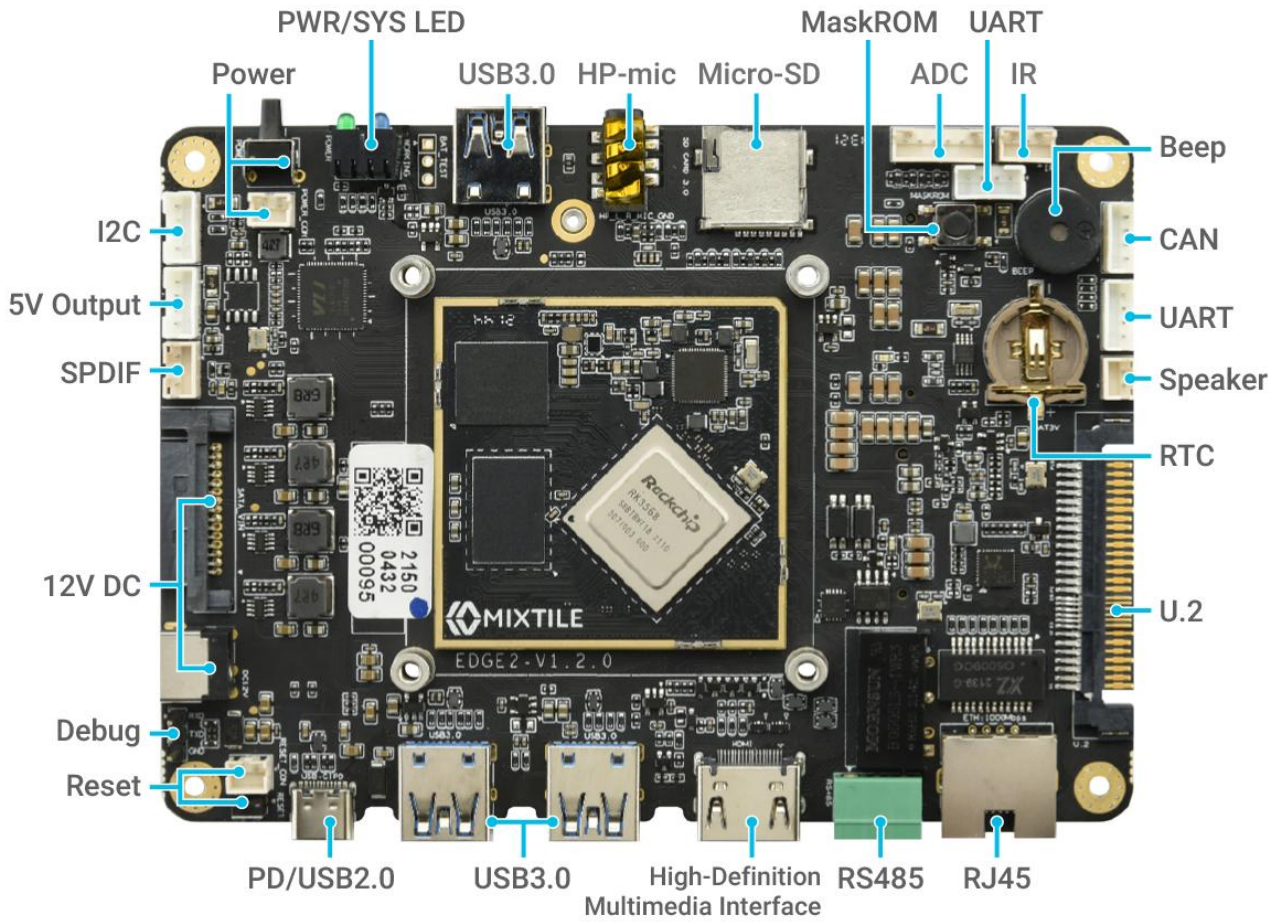

1.4.3 Physical Dimensions

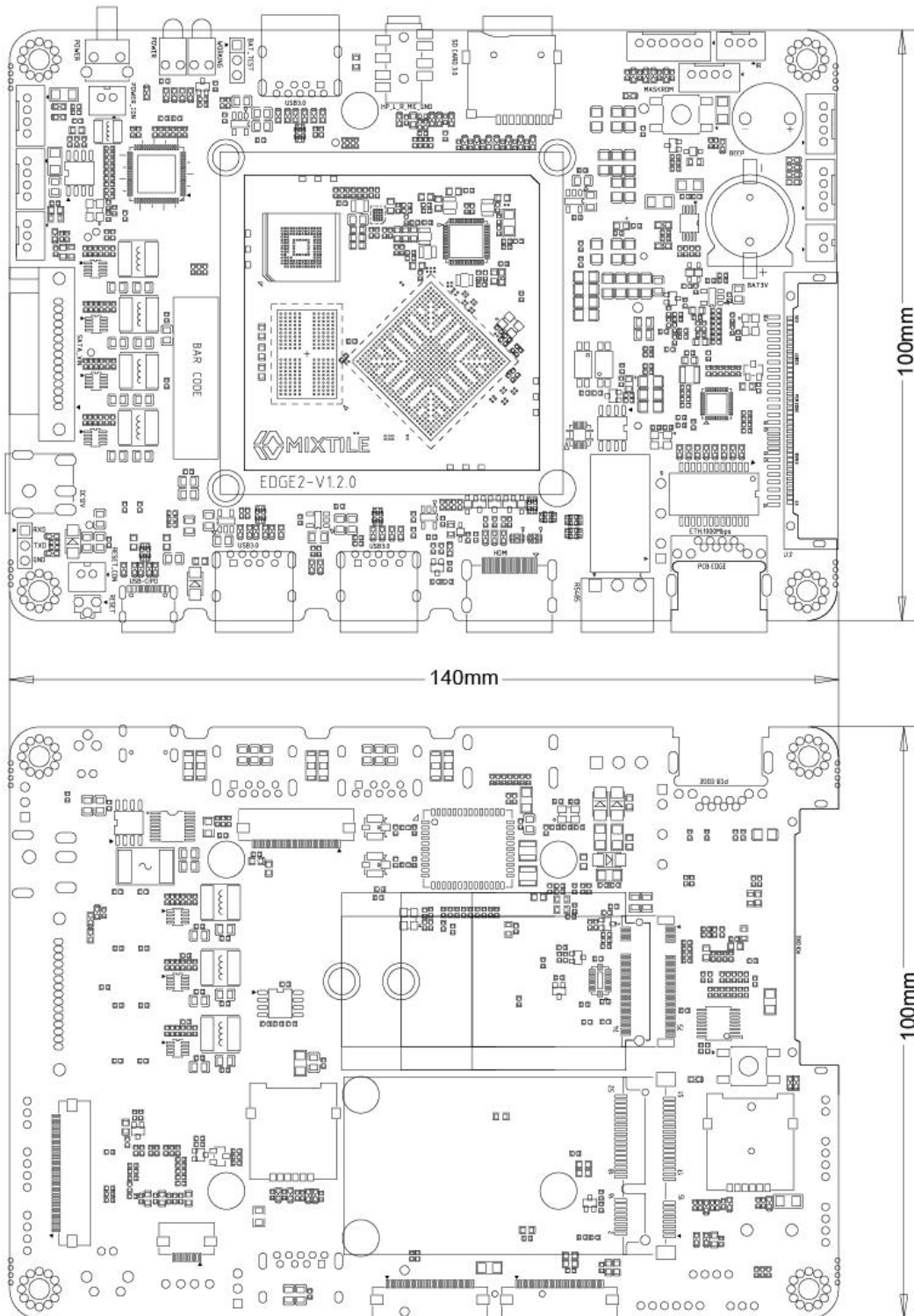

1.5 Key Component Specifications

The key component specifications are described below with relevant hardware information and developing notices. For more information, pin assignments and signal descriptions are listed in Chapter 2, Connectors & Pin Assignments.

1.5.1 MIXTILE Core 3568

The Core 3568 is a System-on-Module that expands all CPU functions to pins with an innovative connector. The Rockchip RK3568 ARM64 CPU contains many peripherals to support multi-purpose.

- Quad Cortex-A55 processing cores
- Core operating frequencies up to 2.0GHz
- Neural Process Unit with processing performance up to 0.8 TOPS
- Support 4k@60fps H.265/H.264/VP9 decoder; 1080P@100fps H.265/H.264 encoder
- LPDDR4 SDRAM supports up to 8GB

The SDRAM is 32bits data width, 4 ranks LPDDR4 memory capacities from 2GBytes to 8GBytes. The system flash memory supports eMMC 5.1 memory capacities from 16GBytes to 256GBytes. The default memory setting is 2/4GBytes LPDDR4 and 16/32GBytes eMMC for Edge 2.

1.5.2 Wi-Fi 6 / Bluetooth

Edge 2 integrates a Wi-Fi and Bluetooth module AP6275S, that can wake up the device from sleep mode. AP6275S supports Wi-Fi 6 and dual-mode Bluetooth 5.0 that could interact with different vendors' 802.11a/b/g/n/ac/ax 2x2 Access Points with MIMO standard and can accomplish up to a speed of 1200Mbps with the dual stream. Wi-Fi wake and enable signals connect to *GPIO0* in the processor, which can be operating while the device is sleep.

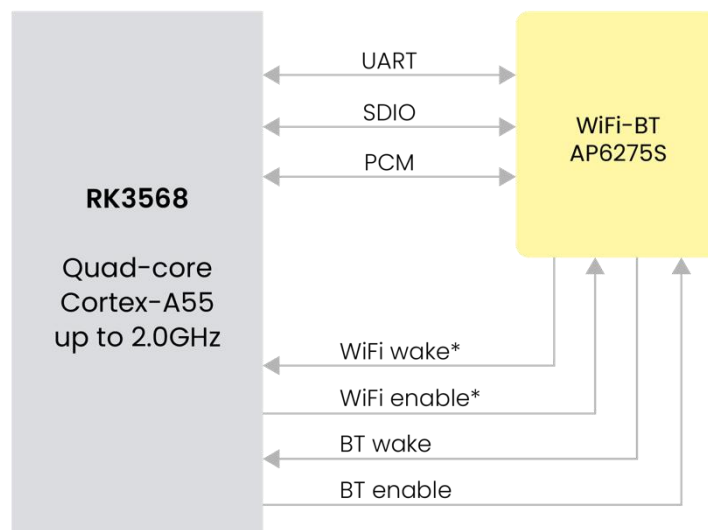

WiFi-BT Module Architecture

1.5.3 MicroSD Socket

The MicroSD socket accepts standard 11mm x 15mm Micro-SD cards with capacities up to 64GBytes. The 4bits data interface supports the SDMMC3.0 protocol. The default boot setting is the eMMC Flash which can change to the MicroSD card.

1.5.4 M.2 Socket

M.2, Next Generation Form Factor (NGFF), is specified for expansion modules. The M.2 interface uses a standard 75 pins B key socket, which supports USB3.0-based WWAN modules, PCIe-based WWAN modules, and PCIe-based SSD modules. The M.2 socket supports the module sizes of 2242, 3042, and 3052.

The module supporting configuration, including power, reset, and interrupt signals, is under software control by Core 3568. Since each module needs specific configuration definitions, check the configuration setting before connecting the module.

SIM Support

The M.2 socket includes a SIM socket with the *SIM_M.2* mark, which supports 12mm x 15mm micro-SIM cards for 4G/5G cellular function. This socket does not support dual SIM.

USB Support

The M.2 socket supports one standard USB 3.0 interface. Since the USB 3.0 data signals and one lane of PCIe data signals are using the same set of pins, a GPIO is used to select USB 3.0 and a lane of two-lane PCIe 3.0 signal.

PCIe Support

The M.2 socket supports a two-lane PCIe 3.0 interface. Edge 2 uses PI6C557-03BLE as a clock generator to provide a 100MHz clock signal for the CPU and M.2 socket. For full functioning of the two-lane PCIe signal, the selecting GPIO, *PCIE_USB_SEL_GPIO1_D0*, needs to set LOW to active.

1.5.5 Mini-PCIe Socket

The mini-PCIe is a small form factor PCI card interface, which uses a standard 52 pins mini-PCIe socket. It contains a USB 2.0 interface with a supported SIM signal. The mini-PCIe socket supports the module sizes of 3052.

The module supporting configuration, including power, reset, and interrupt signals, is under software control by Core 3568. Since each module needs specific configuration definitions, check the configuration setting before connecting the module.

SIM Support

The mini-PCIe socket includes a SIM socket with *SIM_Mini* mark, which supports 12mm x 15mm micro-SIM cards for 4G cellular function. This socket does not support dual SIM.

USB Support

The mini-PCIe socket supports a standard USB 2.0 interface.

1.5.6 Gigabit Ethernet

The IEEE802.3 compliant ethernet supports 10/100/1000Mb half-duplex and full-duplex auto-negotiation. The GbE communicates to an external PHY, RTL8211F-CG, through an RGMII interface from the processor. The RJ45 connector contains status and speed lights. The green light is on for connected and flashing for data transmitting. The yellow light is on for 1000Mbps and off for 10/100Mbps.

1.5.7 Power Input

Power Delivery (PD)

The power port uses a USB-C port, which supports USB PD 3.0 . An on-board Power Delivery controller allows the maximum power input of 20V @ 3A. The Edge 2, as device mode, can be communicated by USB-C, which supports USB 2.0 for ADB debugging, firmware update.

12V DC

DC power inputs from a DC power jack socket or a SATA power socket require 12V @ 3A.

1.5.8 USB 2.0/3.0 Host Ports

Edge 2 has three standard USB 2.0/3.0 host ports using type-A connectors and one USB 2.0/3.0 port connects M.2 socket. These USB 2.0/3.0 ports are provided by a USB 3.0 hub, VL817. The three type-A connectors support 5V at 1A power and dependent software power dis/enabling.

1.5.9 RS485

RS485 connector has three pins, pin A, B, and GND for communication. RS485 connects to *UART4* in CPU via interface IC, SP485REN-L. RS485 is a half-duplex bus with a default setting on receiving state. It will automatically switch to the sending state when needed. RS485 uses full isolation designs, the power supply and ground are isolated from the module used in the board, and the signal is isolated by an optocoupler.

1.5.10 Display Support

The video output processor supports the resolution from 1920x1080@60Hz to 4096x2304@60Hz and three simultaneous displays in the following interfaces. The default main display is High-Definition Multimedia Interface.

High-Definition Multimedia Interface

High-Definition Multimedia Interface display compliant High-Definition Multimedia Interface 1.4 and High-Definition Multimedia Interface 2.0. It supports up to 1920x1080@120Hz and 4096x2304@60Hz resolution.

eDP

The eDP display supports up to 2560x1600@60Hz resolution, up to 4 lanes of 2.7Gbps/lane. The 30-pin FPC connector includes the eDP interface and a backlight source. The pin assignments are listed in the next chapter.

MIPI-DSI

The MIPI-DSI display supports two channel DSI and 2.5Gbps maximum data rate per lane. It supports up to 1920x1080@60Hz display output for single-MIPI mode and 2560x1440@60Hz for dual-MIPI mode. Two MIPI-DIS interfaces use 30-pin FPC connectors, *MIPI-DSIO* and *MIPI-DSII*, which include one channel MIPI-DSI and one touch panel signal (TP).

The connectivity is shown in the following figure:

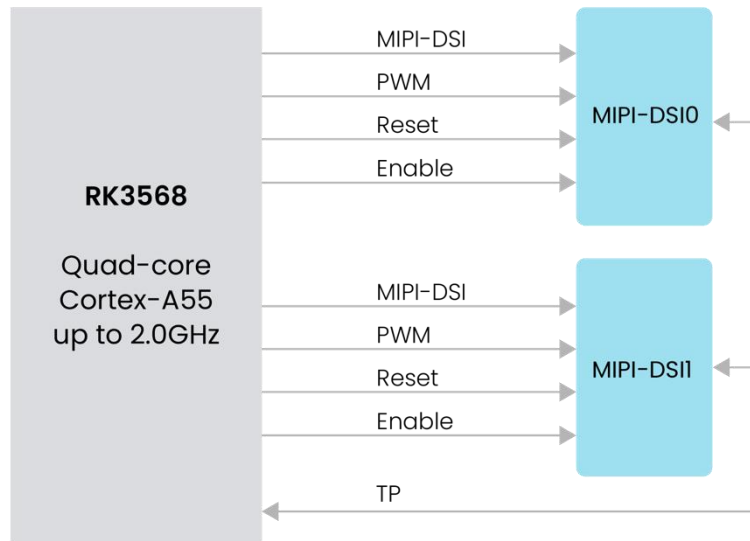

MIPI-DSI Architecture

1.5.11 U.2 Connector

The U.2 interface uses a 68-pin U.2 connector including a standard SATA signal, which supports 5V at 3A maximum, a SATA 3.0/PCIe 2.0 signal, a USB 2.0 signal, and another set of RGMII for ethernet.

1.5.12 Buttons & LEDs

The POWER button controls three statuses of the device, on, off, and sleep. Short press POWER button to turn on device when the device is off, press and hold POWER button to turn off device. Short press POWER button to enter sleep mode when the device is on. Short press RESET button to reset the device. When the device is on, press the RECOVERY button and hold, it will restart and restore the factory settings.

The MASKROM button is for development only, hold the MASKROM button and power up (or reset). The system will enter MaskROM mode for firmware development.

The power and system LEDs indicate the statuses of the power supply and system operating. And two small LEDs on the front side of board indicate the network status of M.2 and mini-PCIe modules.

2 Connectors & Pin Assignments

The following section lists the interfaces connector pin assignments, pin types with corresponding signal descriptions. The interface connectors on Edge 2 are listed in the table below.

2.1 Debug

Pin #	Pin Name	Pin Type	Input/Output	Signal Description
1	UART2_RXD	IO	Input	UART2 serial data input for debug
2	UART2_TXD	IO	Output	UART2 serial data output for debug
3	GND	GND	-	Ground

2.2 UART

UART 3

Pin #	Pin Name	Pin Type	Input/Output	Signal Description
1	3.3V	PWR	Output	3.3V @ 100mA Max
2	UART3_RX	IO	Input	UART3 serial data input
3	UART3_TX	IO	Output	UART3 serial data output
4	GND	GND	-	Ground

UART 5

Pin #	Pin Name	Pin Type	Input/Output	Signal Description
1	3.3V	PWR	Output	3.3V @ 100mA Max
2	UART5_RX	IO	Input	UART5 serial data input
3	UART5_TX	IO	Output	UART5 serial data output
4	GND	GND	-	Ground

2.3 CAN-IO

Pin #	Pin Name	Pin Type	Input/Output	Signal Description
1	5V	PWR	Output	5V @ 200mA Max
2	CAN1_RX	IO	Input	CAN receive data, connect to CAN transceiver
3	CAN1_TX	IO	Output	CAN transmit data, connect to CAN transceiver
4	GND	GND	-	Ground

2.4 I2C

Pin #	Pin Name	Pin Type	Input/Output	Signal Description
1	3.3V	PWR	Output	3.3V @ 100mA Max
2	I2C3_SCL	IO	Output	I2C clock signal
3	I2C3_SDA	IO	I/O	I2C data signal
4	GND	GND	-	Ground

2.5 5V Output

Pin #	Pin Name	Pin Type	Input/Output	Signal Description
1	5V	PWR	Output	5V @ 2A Max in total
2	5V	PWR	Output	5V @ 2A Max in total
3	GND	GND	-	Ground
4	GND	GND	-	Ground

2.6 Power button connector

Pin #	Pin Name	Pin Type	Input/Output	Signal Description
1	PWRON_CON	IO	Input	Active-low, same as PWR button
2	GND	GND	-	Ground

2.7 Reset button connector

Pin #	Pin Name	Pin Type	Input/Output	Signal Description
1	RESET_KEY	IO	Input	Active-low reset signal, same as RESET button
2	GND	GND	-	Ground

2.8 SPDIF

Pin #	Pin Name	Pin Type	Input/Output	Signal Description
1	SPDIF_TX	IO	Output	SPDIF output signal
2	3.3V	PWR	Output	3.3V @ 100mA Max
3	GND	GND	-	Ground

2.9 RS485

Pin #	Pin Name	Pin Type	Input/Output	Signal Description
1	GND	GND	-	Ground
2	485B	DS	I/O	RS485 differential signal Negative
3	485A	DS	I/O	RS485 differential signal Positive

2.10 ADC

Pin #	Pin Name	Pin Type	Input/Output	Signal Description
1	3.3V	PWR	Output	3.3V @ 100mA Max
2	SARADC_VIN4	ANA	Input	ADC analog signal
3	SARADC_VIN5	ANA	Input	ADC analog signal
4	SARADC_VIN6	ANA	Input	ADC analog signal
5	SARADC_VIN7	ANA	Input	ADC analog signal
6	GND	GND	-	Ground

2.11 Speaker

Pin #	Pin Name	Pin Type	Input/Output	Signal Description
1	SPK+	ANA	Output	speaker driver output Positive
2	SPK-	ANA	Output	speaker driver output Negative

2.12 DMIC

Pin #	Pin Name	Pin Type	Input/Output	Signal Description
1	3.3V	PWR	Output	3.3V @ 500mA Max in total
2	3.3V	PWR	Output	3.3V @ 500mA Max in total
3	GND	GND	-	Ground
4	GND	GND	-	Ground
5	PDM_SDI1	IO	Input	PDM data signal
6	PDM_SDI2	IO	Input	PDM data signal
7	PDM_SDI3	IO	Input	PDM data signal
8	GND	GND	-	Ground
9	PDM_CLK1	IO	Output	PDM clock signal
10	GND	GND	-	Ground

2.13 MIPI-DSIO

Pin #	Pin Name	Pin Type	Input/Output	Signal Description
1	GND	GND	-	Ground
2	MIPI_DSI_TX0_D0N	LVDS	Output	MIPI-DSIO data signal Negative
3	MIPI_DSI_TX0_D0P	LVDS	Output	MIPI-DSIO data signal Positive
4	GND	GND	-	Ground
5	MIPI_DSI_TX0_D1N	LVDS	Output	MIPI-DSIO data signal Negative
6	MIPI_DSI_TX0_D1P	LVDS	Output	MIPI-DSIO data signal Positive
7	GND	GND	-	Ground
8	MIPI_DSI_TX0_CLKN	LVDS	Output	MIPI-DSIO clock signal Negative
9	MIPI_DSI_TX0_CLKP	LVDS	Output	MIPI-DSIO clock signal Positive
10	GND	GND	-	Ground
11	MIPI_DSI_TX0_D2N	LVDS	Output	MIPI-DSIO data signal Negative
12	MIPI_DSI_TX0_D2P	LVDS	Output	MIPI-DSIO data signal Positive
13	GND	GND	-	Ground
14	MIPI_DSI_TX0_D3N	LVDS	Output	MIPI-DSIO data signal Negative
15	MIPI_DSI_TX0_D3P	LVDS	Output	MIPI-DSIO data signal Positive
16	GND	GND	-	Ground
17	LCD0_BL_PWM4	IO	Output	PWM Output for backlight adjust
18	NC	-	-	Not connected pin
19	3.3V	PWR	Output	3.3V @ 200mA Max
20	LCD0_RST_L_GPIO1_D1	IO	Output	GPIO output for lcd reset
21	SARADC_VIN2_LCD_ID	ANA	Input	Analog signal Input
22	LCD0_PWREN_H_GPIO0_C7	IO	Output	GPIO output for lcd power on
23	I2C1_SCL_TP	IO	Output	I2C clock signal for touch panel
24	I2C1_SDA_TP	IO	I/O	I2C data signal for touch panel
25	TP_INT_L_GPIO0_B5	IO	Input	GPIO for touch panel interrupt
26	TP_RST_L_GPIO0_B6	IO	Output	GPIO for touch panel reset
27	GND	GND	-	Ground
28	5V	PWR	Output	5V @ 500mA Max in total
29	5V	PWR	Output	5V @ 500mA Max in total
30	5V	PWR	Output	5V @ 500mA Max in total

2.14 MIPI-DSI1

Pin #	Pin Name	Pin Type	Input/Output	Signal Description
1	GND	GND	-	Ground
2	MIPI_DSI_TX1_D0N	LVDS	Output	MIPI-DSI1 data signal Negative

3	MIPI_DSI_TX1_D0P	LVDS	Output	MIPI-DSI1 data signal Positive
4	GND	GND	-	Ground
5	MIPI_DSI_TX1_D1N	LVDS	Output	MIPI-DSI1 data signal Negative
6	MIPI_DSI_TX1_D1P	LVDS	Output	MIPI-DSI1 data signal Positive
7	GND	GND	-	Ground
8	MIPI_DSI_TX1_CLKN	LVDS	Output	MIPI-DSI1 clock signal Negative
9	MIPI_DSI_TX1_CLKP	LVDS	Output	MIPI-DSI1 clock signal Positive
10	GND	GND	-	Ground
11	MIPI_DSI_TX1_D2N	LVDS	Output	MIPI-DSI1 data signal Negative
12	MIPI_DSI_TX1_D2P	LVDS	Output	MIPI-DSI1 data signal Positive
13	GND	GND	-	Ground
14	MIPI_DSI_TX1_D3N	LVDS	Output	MIPI-DSI1 data signal Negative
15	MIPI_DSI_TX1_D3P	LVDS	Output	MIPI-DSI1 data signal Positive
16	GND	GND	-	Ground
17	PWM5	IO	Output	PWM Output for backlight adjust
18	NC	-	-	Not connected pin
19	3.3V	PWR	Output	3.3V @ 200mA Max
20	LCD1_RST_L_GPIO3_B6	IO	Output	GPIO output for lcd reset
21	SARADC_VIN2_LCD_ID	ANA	Input	Analog signal Input
22	LCD1_PWREN_H_GPIO4_D2	IO	Output	GPIO output for lcd power enable
23	I2C1_SCL_TP	IO	Output	I2C clock signal for touch panel
24	I2C1_SDA_TP	IO	I/O	I2C data signal for touch panel
25	TP_INT_L_GPIO0_B5	IO	Input	GPIO for touch panel interrupt
26	TP_RST_L_GPIO0_B6	IO	Output	GPIO for touch panel reset
27	GND	GND	-	Ground
28	5V	PWR	Output	5V @ 500mA Max in total
29	5V	PWR	Output	5V @ 500mA Max in total
30	5V	PWR	Output	5V @ 500mA Max in total

2.15eDP

Pin #	Pin Name	Pin Type	Input/Output	Signal Description
1	GND	GND	-	Ground
2	EDP_TX_D1N	LVDS	Output	EDP data signal Negative
3	EDP_TX_D1P	LVDS	Output	EDP data signal Positive
4	GND	GND	-	Ground
5	EDP_TX_D0N	LVDS	Output	EDP data signal Negative
6	EDP_TX_D0P	LVDS	Output	EDP data signal Positive
7	GND	GND	-	Ground
8	EDP_TX_AUXN_CON	LVDS	Output	EDP clock signal Negative
9	EDP_TX_AUXP_CON	LVDS	Output	EDP clock signal Positive
10	GND	GND	-	Ground

11	EDP_TX_D2N	LVDS	Output	EDP data signal Negative
12	EDP_TX_D2P	LVDS	Output	EDP data signal Positive
13	GND	GND	-	Ground
14	EDP_TX_D3N	LVDS	Output	EDP data signal Negative
15	EDP_TX_D3P	LVDS	Output	EDP data signal Positive
16	3.3V	PWR	Output	3.3V @ 500mA Max in total
17	3.3V	PWR	Output	3.3V @ 500mA Max in total
18	GND	GND	-	Ground
19	GND	GND	-	Ground
20	EDP_HPD_GPIO0_C2	IO	Input	eDP hot plug detect signal
21	GND	GND	-	Ground
22	GND	GND	-	Ground
23	GND	GND	-	Ground
24	GND	GND	-	Ground
25	EDP_BL_EN_GPIO3_C1	IO	Output	Output for enable backlight power
26	EDP_PWM12_GPIO4_C5	IO	Output	PWM Output for backlight adjust
27	GND	GND	-	Ground
28	12V	PWR	Output	12V power supply for backlight
29	12V	PWR	Output	12V power supply for backlight,
30	12V	PWR	Output	12V power supply for backlight

2.16 Camera

Pin #	Pin Name	Pin Type	Input/Output	Signal Description
1	GND	GND	-	Ground
2	MIPI_CSI_RX_D0N	LVDS	Input	MIPI_CSI data signal Negative
3	MIPI_CSI_RX_D0P	LVDS	Input	MIPI_CSI data signal Positive
4	GND	GND	-	Ground
5	MIPI_CSI_RX_D1N	LVDS	Input	MIPI_CSI data signal Negative
6	MIPI_CSI_RX_D1P	LVDS	Input	MIPI_CSI data signal Positive
7	GND	GND	-	Ground
8	MIPI_CSI_RX_CLK0N	LVDS	Input	MIPI_CSI clock signal Negative
9	MIPI_CSI_RX_CLK0P	LVDS	Input	MIPI_CSI clock signal Positive
10	GND	GND	-	Ground
11	MIPI_CSI_RX_D2N	LVDS	Input	MIPI_CSI data signal Negative
12	MIPI_CSI_RX_D2P	LVDS	Input	MIPI_CSI data signal Positive
13	GND	GND	-	Ground
14	MIPI_CSI_RX_D3N	LVDS	Input	MIPI_CSI data signal Negative
15	MIPI_CSI_RX_D3P	LVDS	Input	MIPI_CSI data signal Positive
16	GND	GND	-	Ground
17	CIF_CLKOUT	IO	Output	CLOCK output for camera
18	GND	GND	-	Ground

19	NC	-	-	Not connected pin
20	CAMERA0_RST_L_GPIO4_B5	IO	Output	GPIO output for camera reset
21	CAMERA0_PDN_L_GPIO4_B4	IO	Output	GPIO output for camera disable
22	CAMERA0_PWREN_GPIO1_D4	IO	Output	GPIO output for camera enable
23	I2C4_SCL_M0	IO	Output	I2C clock signal
24	I2C4_SDA_M0	IO	Input	I2C data signal
25	PWM14_M0	IO	Output	PWM Output signal
26	GND	GND	-	Ground
27	GND	GND	-	Ground
28	5V	PWR	Output	5V @ 500mA Max in total
29	5V	PWR	Output	5V @ 500mA Max in total
30	5V	PWR	Output	5V @ 500mA Max in total
31	GND	GND	-	Ground
32	NC	-	-	Not connected pin
33	NC	-	-	Not connected pin
34	NC	-	-	Not connected pin
35	GND	GND	-	Ground
36	MIPI_MCLK1	IO	Output	CLOCK output for camera
37	GND	GND	-	Ground
38	MIPI_CSI_RX_CLK1N	LVDS	Input	MIPI_CSI clock signal Negative
39	MIPI_CSI_RX_CLK1P	LVDS	Input	MIPI_CSI clock signal Positive
40	GND	GND	-	Ground

2.17M.2

Pin #	Pin Name	Pin Type	Input/Output	Signal Description
1	NC	-	-	Not connected pin
2	3.3V	PWR	Output	3.3V @ 3A Max in total
3	GND	GND	-	Ground
4	3.3V	PWR	Output	3.3V @ 3A Max in total
5	GND	GND	-	Ground
6	M2_ONOFF_GPIO1_D2	IO	Output	GPIO output for on or off to module
7	HUB_HOST3_DP	LVDS	I/O	USB2.0 data signal Positive
8	NC	-	-	Not connected pin
9	HUB_HOST3_DM	LVDS	I/O	USB2.0 data signal Negative
10	M2_LED1	IO	Input	Connect negative for network status
11	GND	GND	-	Ground
20	NC	-	-	Not connected pin
21	NC	-	-	Not connected pin
22	NC	-	-	Not connected pin
23	M2_WAKE_GPIO0_B7	IO	Input	GPIO for module to wakeup CPU
24	NC	-	-	Not connected pin

25	NC	-	-	Not connected pin
26	NC	-	-	Not connected pin
27	GND	GND	-	Ground
28	NC	-	-	Not connected pin
29	PCIE30_TX1_N/HUB_USB3_SSTXN	LVDS	Output	PCIE3.0/USB3.0 data signal Negative
30	M2_UIM_RESET	IO	Input	Reset signal to SIM socket
31	PCIE30_TX1_P/HUB_USB3_SSTXP	LVDS	Output	PCIE3.0/USB3.0 data signal Positive
32	M2_UIM_CLK	IO	Input	Clock signal to SIM socket
33	GND	GND	-	Ground
34	M2_UIM_DATA	IO	Input	data signal to SIM socket
35	PCIE30_RX1N/HUB_USB3_SSRXN	LVDS	Input	PCIE3.0/USB3.0 data signal Negative
36	M2_UIM_PWR	IO	Input	power to SIM socket
37	PCIE30_RX1P/HUB_USB3_SSRXP	LVDS	Input	PCIE3.0/USB3.0 data signal Positive
38	NC	-	-	Not connected pin
39	GND	GND	-	Ground
40	NC	-	-	Not connected pin
41	PCIE30_TX0_N	LVDS	Output	PCIE3.0 data signal output Negative
42	NC	-	-	Not connected pin
43	PCIE30_TX0_P	LVDS	Output	PCIE3.0 data signal output Positive
44	NC	-	-	Not connected pin
45	GND	GND	-	Ground
46	NC	-	-	Not connected pin
47	PCIE30_RX0N	LVDS	Input	PCIE3.0 data signal input Negative
48	NC	-	-	Not connected pin
49	PCIE30_RX0P	LVDS	Input	PCIE3.0 data signal input Positive
50	PCIE30X2_PERSTN_M1	IO	Output	PCIe warm reset request
51	GND	GND	-	Ground
52	PCIE30X2_CLKREQN_M1	IO	Input	clock request from PCIe peripheral
53	CLK0N_CON	LVDS	Output	PCIE3.0 clock signal output Negative
54	PCIE30X2_WAKEN_M1	IO	Input	PCIe wake up
55	CLK0P_CON	LVDS	Output	PCIE3.0 clock signal output Positive
56	NC	-	-	Not connected pin
57	GND	GND	-	Ground
58	NC	-	-	Not connected pin
59	NC	-	-	Not connected pin
60	NC	-	-	Not connected pin
61	NC	-	-	Not connected pin
62	NC	-	-	Not connected pin
63	NC	-	-	Not connected pin
64	NC	-	-	Not connected pin
65	NC	-	-	Not connected pin
66	M2_SIM_DETECT	IO	Output	Card detect signal to SIM socket
67	M2_RESET_GPIO3_B5	IO	Output	GPIO output for reset to module

68	CLK32K_OUT0	IO	Output	Clock output 32.768K to module
69	NC	-	-	Not connected pin
70	3.3V	PWR	Output	3.3V @ 3A Max in total
71	GND	GND	-	Ground
72	3.3V	PWR	Output	3.3V @ 3A Max in total
73	GND	GND	-	Ground
74	3.3V	PWR	Output	3.3V @ 3A Max in total
75	NC	-	-	Not connected pin

2.18 Mini-PCIE

Pin #	Pin Name	Pin Type	Input/Output	Signal Description
1	WAKEUP_MINIPICIE_GPIO0_C1	IO	Input	GPIO for module to wakeup CPU
2	3.3V	PWR	Output	3.3V @ 3A Max in total
3	NC	-	-	Not connected pin
4	GND	GND	-	Ground
5	NC	-	-	Not connected pin
6	NC	-	-	Not connected pin
7	NC	-	-	Not connected pin
8	UIM_PWR	PWR	Input	SIM power supply
9	GND	GND	-	Ground
10	UIM_DATA	IO	Input	SIM data signal
11	NC	-	-	Not connected pin
12	UIM_CLK	IO	Input	SIM clock signal
13	NC	-	-	Not connected pin
14	UIM_RESET	IO	Input	SIM reset signal
15	GND	GND	-	Ground
16	NC	-	-	Not connected pin
17	NC	-	-	Not connected pin
18	GND	GND	-	Ground
19	NC	-	-	Not connected pin
20	NC	-	-	Not connected pin
21	GND	GND	-	Ground
22	MiniPCIE_reset_GPIO3_D4	IO	Output	GPIO output for reset to module
23	NC	-	-	Not connected pin
24	3.3V	PWR	Output	3.3V @ 3A Max in total
25	NC	-	-	Not connected pin
26	GND	GND	-	Ground
27	GND	GND	-	Ground
28	NC	-	-	Not connected pin
29	GND	GND	-	Ground
30	NC	-	-	Not connected pin

31	NC	-	-	Not connected pin
32	NC	-	-	Not connected pin
33	NC	-	-	Not connected pin
34	GND	GND	-	Ground
35	GND	GND	-	Ground
36	USB2_HOST2_DM	LVDS	I/O	USB2.0 data signal Negative
37	NC	-	-	Not connected pin
38	USB2_HOST2_DP	LVDS	I/O	USB2.0 data signal Positive
39	3.3V	PWR	Output	3.3V @ 3A Max in total
40	GND	GND	-	Ground
41	3.3V	PWR	Output	3.3V @ 3A Max in total
42	LED	IO	Input	System status LED
43	NC	-	-	Not connected pin
44	SIM_DETECT	IO	Output	SIM detect
45	NC	-	-	Not connected pin
46	NC	-	-	Not connected pin
47	NC	-	-	Not connected pin
48	NC	-	-	Not connected pin
49	NC	-	-	Not connected pin
50	GND	GND	-	Ground
51	NC	-	-	Not connected pin
52	3.3V	PWR	Output	3.3V @ 3A Max in total

2.19U.2

Pin #	Pin Name	Pin Type	Input/Output	Signal Description
1	GND	GND	-	Ground
2	SATA0_SSRXP	LVDS	Input	SATA data signal input Positive
3	SATA0_SSRXN	LVDS	Input	SATA data signal input Negative
4	GND	GND	-	Ground
5	SATA0_SSTXN	LVDS	Output	SATA data signal output Negative
6	SATA0_SSTXP	LVDS	Output	SATA data signal output Positive
7	GND	GND	-	Ground
8	GMAC0_TXEN	IO	Output	RGMI signal
9	GMAC0_RXD2	IO	Input	RGMI signal
10	NC	-	-	Not connected pin
11	GMAC0_RXD3	IO	Input	RGMI signal
12	GMAC0_RXD0	IO	Input	RGMI signal
13	GMAC0_RXD1	IO	Input	RGMI signal
14	NC	-	-	Not connected pin
15	I2C3_SCL_M0	IO	Output	I2C clock signal
16	I2C3_SDA_M0	IO	I/O	I2C data signal

17	GND	GND	-	Ground
18	GND	GND	-	Ground
19	GND	GND	-	Ground
20	5V	PWR	Output	5V @ 3A Max
21	5V	PWR	Output	5V @ 3A Max
22	5V	PWR	Output	5V @ 3A Max
23	GND	GND	GND	Ground
24	NC	-	-	Not connected pin
25	GND	GND	-	Ground
26	NC	-	-	Not connected pin
27	NC	-	-	Not connected pin
28	NC	-	-	Not connected pin
29	SATA0_LED	IO	Output	SATA0 status for LED
30	SATA2_LED	IO	Output	SATA2 status for LED
31	GMAC0_MCLKINOUT	IO	I/O	CLOCK output 125MHz for GMAC0
32	GND	GND	-	Ground
33	ETH0_REFCLKO_25M	IO	Output	CLOCK output 25MHz for GMAC0
34	GMAC0_MDIO	IO	I/O	GMAC management interface data
35	GND	GND	-	Ground
36	GMAC0_MDC	IO	Output	GMAC management interface clock
37	GMAC0_RXDV_CRS	IO	Input	RGMI signal
38	GND	GND	-	Ground
39	NC	-	-	Not connected pin
40	NC	-	-	Not connected pin
41	GND	GND	-	Ground
42	NC	-	-	Not connected pin
43	NC	-	-	Not connected pin
44	GND	GND	-	Ground
45	USB2_USB3_DM	LVDS	I/O	USB2.0 data signal Negative
46	USB2_USB3_DP	LVDS	I/O	USB2.0 data signal Positive
47	GND	GND	-	Ground
48	GMAC0_RSTN_GPIO2_D3	IO	Output	RGMI signal
49	GMAC0_INT/PMEB_GPIO2_D2	IO	Input	RGMI signal
50	GND	GND	-	Ground
51	GMAC0_RXCLK	IO	Output	RGMI signal
52	GND	GND	-	Ground
53	GMAC0_TXD3	IO	Output	RGMI signal
54	GMAC0_TXD2	IO	Output	RGMI signal
55	GND	GND	-	Ground
56	GMAC0_TXD1	IO	Output	RGMI signal
57	GMAC0_TXD0	IO	Output	RGMI signal
58	GND	GND	-	Ground
59	GMAC0_TXCLK	IO	Output	RGMI signal

60	GND	GND	-	Ground
61	SATA2_TXN	LVDS	Output	SATA data signal output Negative
62	SATA2_TXP	LVDS	Output	SATA data signal output Positive
63	GND	GND	-	Ground
64	SATA2_RXN	LVDS	Input	SATA data signal Input Negative
65	SATA2_RXP	LVDS	Input	SATA data signal Input Positive
66	GND	GND	-	Ground
67	PCIE20_REFCLKN	LVDS	Output	PCIE2.0 reference clock Negative
68	PCIE20_REFCLKP	LVDS	Output	PCIE2.0 reference clock Positive

2.20 SATA Power

Pin #	Pin Name	Pin Type	Input/Output	Signal Description
1	ADC_VIN3	ANA	Input	Measure external voltage, 1.8V Max
2	I2C0_SCL	IO	Output	I2C clock signal
3	I2C0_SDA	IO	I/O	I2C data signal
4	GND	GND	-	Ground
5	GND	GND	-	Ground
6	GND	GND	-	Ground
7	NC	-	-	Not connected pin
8	NC	-	-	Not connected pin
9	NC	-	-	Not connected pin
10	GND	GND	-	Ground
11	GND	GND	-	Ground
12	GND	GND	-	Ground
13	VIN_12V	PWR	Input	12V @ 3A
14	VIN_12V	PWR	Input	12V @ 3A
15	VIN_12V	PWR	Input	12V @ 3A

3 Specifications

3.1 Environmental

Parameter	Specifications
Operating Temperature	0 ° to +70 °C
Storage Temperature	0 ° to +70 °C

3.2 Mechanical

Parameter	Specifications
PCBA dimensions, Length x Width	140mm x 100mm
Edge 2 dimensions, Length x Width x Height	148mm x 105mm x 32mm

Weight, Device (Board)	665g (113g)
------------------------	-------------

4 Support

4.1 Technical Support

MIXTILE technical support team assists you with the questions you may have. Contact us with the following methods below.

Email: support@mixtile.com

Website: <https://www.mixtile.com>